



Operating Manual

**Mixing pump G 4 X Super / G 4 X XL
Part 2 EC Declaration of Conformity
Overview - Operation and service**



Article number of the operating manual: 00 43 75 47

Article number of the machine: 00 41 41 71

Article number of the machine: 00 41 41 89

Article number of the machine: 00 42 39 47

Article number of the machine: 00 40 67 95



Read the operating manual prior to starting any work!

© Knauf PFT GmbH & Co. KG
P.O. Box no. 60 97343 Iphofen
Einersheimer Straße 53 97346 Iphofen
Germany

Phone: +49 (0) 93 23/31-760
Fax: +49 (0) 0 93 23/31-770
Technical hotline +49 9323 31-1818

info@pft-iphofen.de
Internet: www.pft.eu



1 EC Declaration of Conformity.....	6	11 Operating modes	16
2 Examination	7	11.1 Selector switch star wheel.....	16
2.1 Examination by machine operator	7	11.2 Selector switch pressure booster pump	16
2.2 Periodic inspection.....	7	12 Accessories	17
3 General information	8	13 Intended use Control panel	18
3.1 Information regarding the operating manual	8	13.1 Intended purpose control panel.....	18
3.2 Keep the manual for future reference	8	13.2 Intended purpose solenoid valve	18
3.3 Division	8	13.3 Intended purpose flow meter.....	18
3.4 Spare parts lists	8	14 Intended use air compressor.....	19
4 Technical data.....	9	14.1 Intended purpose air compressor	19
4.1 General information	9	14.2 Safety systems air compressor	20
4.2 Power connection	9	14.3 General positioning of the air compressor.....	20
4.3 Operating conditions	9	14.4 Hot surface of the air compressor	20
4.4 Power values Pump unit D6-3	10	15 Description G 4 X SUPER / G 4 X XL.....	21
4.5 Power values pump unit D6-4.....	10	15.1 Functional principle G 4 X SUPER / G 4 X XL.....	21
4.6 Sound power level	11	15.2 Functional description G 4 X SUPER / G 4 X XL.....	21
4.7 Vibrations	11	15.3 Fields of application.....	21
5 Dimension sheet.....	11	16 Material:.....	22
6 Name plate	12	16.1 Flowability / Flow characteristics	22
7 Quality Control sticker	12	17 Mortar pressure gauge	22
8 Assembly.....	13	18 Safety rules	22
8.1 Overview	13	19 Transport, packing and storage	23
9 Description of assemblies	14	19.1 Safety instructions for transport	23
9.1 Hopper	14	19.2 Transport inspection	24
9.2 Control cabinet item number 00 25 46 66.....	14	19.3 Transport	24
9.3 Mixing tube with motor and pump.....	15	19.4 Transport with van.....	24
9.4 Water tap	15	19.5 Transport in individual parts	25
9.5 Air compressor K2 N with pressure switch-off.....	15	20 Packaging.....	26
10 Connections.....	16		

Table of Contents



21 Operation	26		
21.1 Safety	26		
22 Safety system	27		
23 System monitoring	27		
23.1 Idle-running protection	27		
24 Preparing the machine	28		
25 Connecting the power supply 400 V	28		
25.1 Check the individual connectors	29		
26 Connecting the water supply	29		
26.1 Close water draining cocks	29		
26.2 Connecting the water supply	30		
26.3 Connection of water from water tank ...	30		
27 Switching on the G 4 X	31		
27.1 Putting the machine into operation	31		
27.2 Set water quantity	31		
27.3 Soaking of the mixing section	32		
28 Mortar pressure gauge	32		
29 Hazardous dusts	32		
29.1 Anti-dust unit G 4	33		
30 Feeding dry material to the machine	33		
31 Monitoring the machine	34		
32 Putting the machine into operation	34		
32.1 Check consistency of mortar	34		
32.2 Start the machine in a “flying” mode	34		
33 Mortar hoses	35		
33.1 Prepare mortar hoses	35		
33.2 Connect mortar hose	36		
34 Compressed air supply	36		
34.1 Connect air hose	36		
34.2 Connecting the spraying gun	37		
		34.3 Switch on air compressor	37
35 Apply mortar	37		
35.1 Open the air tap at the spraying gun ...	38		
35.2 Interruption of work	39		
35.3 In case of longer interruption of work/break	39		
35.4 Switch off air compressor	39		
36 Remote control	40		
36.1 Working with the remote control	40		
37 Stopping in case of emergency			
Emergency-stop switch	40		
37.1 Emergency-stop switch	40		
38 Measures in case of power cut	41		
38.1 Relieve mortar pressure	41		
38.2 Relieve mortar pressure	41		
39 Work on troubleshooting	42		
39.1 Reaction in the event of faults	42		
39.2 Fault displays	43		
39.3 Faults	43		
39.4 Safety	43		
39.5 Table of faults	44		
39.6 Signs for hose blockages:	46		
39.7 Causes for this can be:	47		
39.8 Earlier damage to the mortar hose	47		
40 Removal of blockages in the hose	47		
40.1 Change the direction of rotation of the mixing pump motor in case of blockages in the hose	48		
40.2 Blockage does not dislodge	48		
40.3 Switch the machine back on after the blockage has been removed	49		
41 Cleaning the machine after work	49		
41.1 Empty the mixing tube	49		
41.2 Secure against restarting	50		
41.3 Cleaning the G 4 X	50		
41.4 Decouple mortar hose	50		
41.5 Clean mortar hose	51		
41.6 Remove the water hose	51		



Table of Contents

41.7 Cleaning the mixing tube	52	45.1 Safety	57
41.8 Insert the mixing tube cleaner.....	52	45.2 Remove connection cable.....	57
41.9 Insert the mixing tube cleaner.....	52	45.3 Environmental protection.....	58
41.10 Insert agitator	53	45.4 Maintenance plan	58
41.11 Cleaning the hopper	53	45.5 Maintenance work	59
42 Changing the pump / Cleaning the pump	54	45.6 Safety valve air compressor	61
42.1 Fold up mixing tube	54	45.7 Adjust locking lever	61
43 Switch off G 4 X	55	45.8 Measures after effected maintenance..	61
44 Measures in case of risk of frost... 55		46 Disassembly.....	62
44.1 Blow dry water fitting.....	56	46.1 Safety	62
44.2 Switch on air compressor	56	46.2 Disassembly	63
45 Maintenance.....	57	47 Disposal.....	63
		48 Index	64

EC Declaration of Conformity



1 EC Declaration of Conformity

Company: Knauf PFT GmbH & Co. KG
Einersheimer Straße 53
97346 Iphofen
Germany

declares under our sole responsibility that the product:

Type of machine: G 4 X
Type of equipment: Mixing pump
Serial number:
Guaranteed sound power level: 78 dB 95 dB

is in conformity with the following CE directives:

- Outdoor directive (2000/14/EC),
- Machine directive (2006/42/EC),
- Electromagnetic Compatibility Directive (2004/108/EC).

Operative Conformity Assessment according to Outdoor Directive 2000/14/EC:

Internal production control as per article 14 paragraph 2 in connection with annex V.

This declaration only refers to the machine in the state in which it has been placed on the market. Parts subsequently added by the user and/or subsequent interventions are not covered. This declaration ceases to be valid if the product is converted or changed without consent.

Person authorised to compile the relevant technical documentation:

Diploma in industrial engineering (FH) Michael Duelli, Einersheimer Straße 53, 97346 Iphofen.

The technical documentation is available from:

Knauf PFT GmbH & Co.KG, Technical Department, Einersheimer Straße 53, 97346 Iphofen.

Iphofen

Place, date of issue

Name and signature

Dr. York Falkenberg

Managing director
Details of signatory

2 Examination

2.1 Examination by machine operator

- Prior to each shift, the machine operator has to examine the effectiveness of the control and safety devices as well as the proper fitting of the protection devices.
- The safe working condition of construction machinery has to be checked by the machine operator during operation.
- If the safety devices show any defects or if any other defects are detected that compromise a safe operation, the supervisor has to be informed immediately.
- In case of defects that cause harm to persons, the operation of the construction machine has to be stopped to eliminate the defects.

2.2 Periodic inspection

- Construction machinery has to be inspected for their safe working condition in accordance with the operating conditions and the operational requirements as needed, however at least once a year by an expert.
- Pressure vessels have to undergo the prescribed expert inspections.
- The inspection results have to be documented and kept at least until the next inspection.

3 General information

3.1 Information regarding the operating manual

This operating manual gives important information on handling the device. A prerequisite for safe working is the observance of all stated safety guidelines and instructions.

Furthermore the local accident prevention guidelines and general safety instructions for the application area of the device are to be adhered to.

Read the operating manual thoroughly before starting any work! It is a part of the product and has to be kept near the tool and easily accessible to the staff at all times.

If the tool is given to third parties, also include the operating manual.

The figures in this manual are for presentation purposes of facts not necessarily to scale and may slightly differ from the actual model of the device.

3.2 Keep the manual for future reference

The operating manual has to be available during the whole service life of the product.

3.3 Division

The operating manual is divided into 2 books:

- Part 1 Safety

General safety instructions mixing pumps/feed pumps

Article number: 00 17 27 09

- Part 2 Overview, operation and service (this manual).

For safe operation of the device both parts have to be read and observed. Together they form one operating manual.

3.4 Spare parts lists

Spare parts lists for the machine can be found on the Internet at www.pft.eu.

4 Technical data

4.1 General information

Individual weights

Detail	Value	Unit
Weight approx.	308 / 320	kg
Length	1200	mm
Width	720	mm
Height	1530 / 1660	mm

Detail	Value	Unit
Weight pump motor with tilt flange	51 / 63	kg
Weight of mixing pump module	81	kg
Weight of hopper module	152	kg
Weight of air compressor	24	kg

Hopper dimensions

Detail	Value	Unit
Filling height	910 / 940	mm
Hopper volume	145	l
Hopper capacity with attachment	200	l

4.2 Power connection



Fig. 1: Motor protection switch

	Power	Setting value	Designation
Star wheel	0.75 kW	2.2 A	Q5
Mixer motor	5.5 kW / 7.5	11 A / 15 A	Q6
Compressor	0.9 kW	1.8 A	Q2
Water pump	0.5 kW	1.7A	Q4

Water connection

Detail	Value	Unit
Operating pressure, max.	2.5	bar
Connection	3/4	inch

4.3 Operating conditions

Environment

Detail	Value	Unit
Temperature range	2-45	°C
Relative humidity, max.	80	%

Technical data

Duration

Detail	Value	Unit
Max. operating time at a stretch	8	hours

Electrical details

Detail	Value	Unit
voltage, three-phase current 50 Hz	400	V
Power consumption, max.	32	A
Power input, max.	7.7 / 9.7	kW
Fuse protection, at least	3 x 25	A
Speed pump motor approx.	385 / 400	rpm
Speed star wheel motor	28	rpm

4.4 Power values Pump unit D6-3

Detail	Value	Unit
Pump capacity, approx.	22	l/min at 385 rpm
Operating pressure, max.	30	bar
Grain size max.	3	mm
Feed range *, max. at 25 mm \varnothing	30	m
Feed range *, max. at 35 mm \varnothing	50	m
Compressor output K2 N	0.25	Nm ³ /min

* reference value depending on conveying height, pump condition and version, mortar quality, composition and consistency

4.5 Power values pump unit D6-4

Particular	Value	Unit
Pump capacity, approx.	23	l/min at 400 rpm
Operating pressure, max.	40	bar
Grain size max.	3	mm
Feed range *, max. at 35 mm \varnothing	65	m

* reference value depending on conveying height, pump condition and version, mortar quality, composition and consistency

4.6 Sound power level

Guaranteed sound power level LWA

95dB (A)

4.7 Vibrations

Weighted effective value of acceleration to which the upper body parts are exposed <2.5 m/s²

5 Dimension sheet

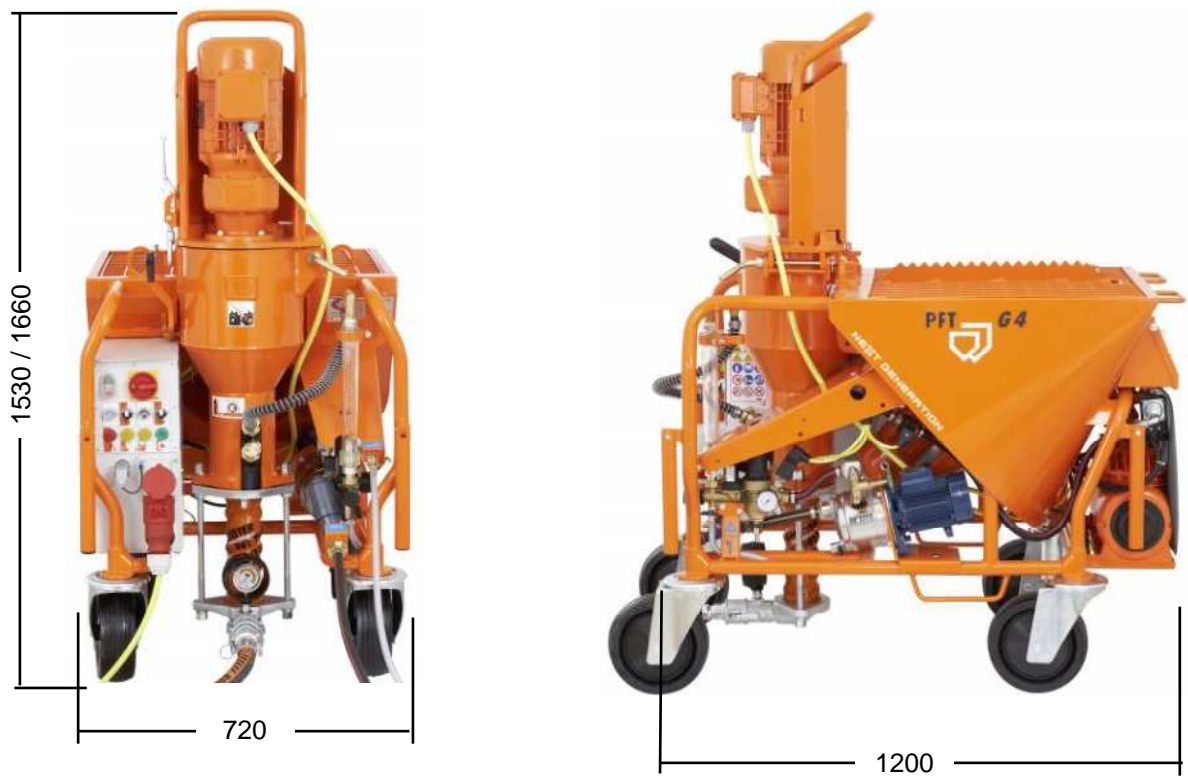

Fig. 2: Dimension sheet

6 Name plate



Fig. 3: Name plate

The type plate is located at the right bottom of the hopper and includes the following information:

- Manufacturer
- Type
- Year of manufacture
- Machine number
- Permissible operating pressure

7 Quality Control sticker



Fig. 4: Quality Control sticker

The following details can be found on the Quality Control sticker:

- CE confirmed as per EU directives
- Serial no / serial number
- Controller / signature
- Date of control

8 Assembly

8.1 Overview

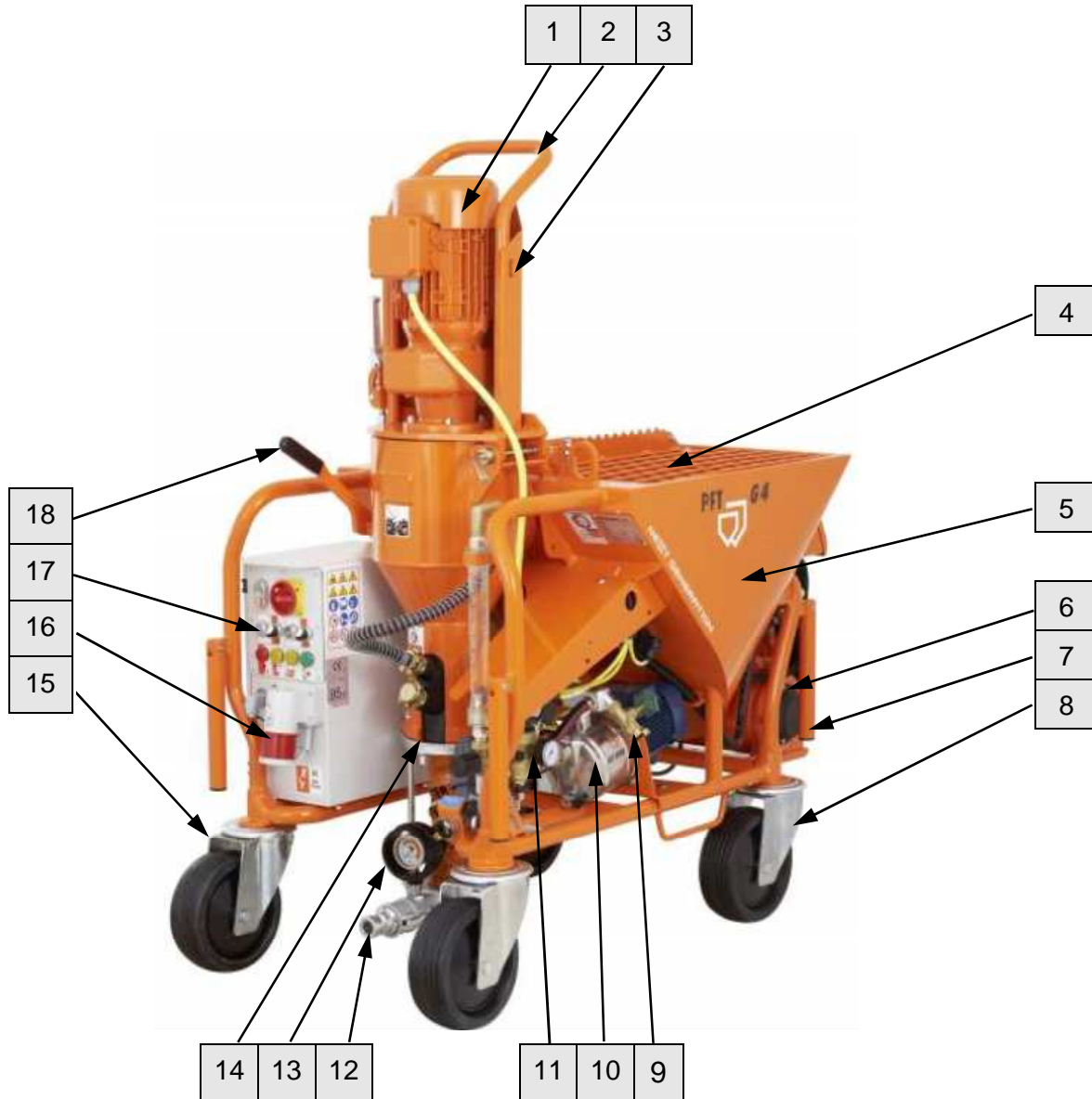

Fig. 5: Table of the assembly groups

- | | |
|---------------------------------------|---|
| 1. Pump motor | 10. Booster pump |
| 2. Motor protection handle | 11. Water tap |
| 3. Deflector plate | 12. Connection for mortar hose |
| 4. Protective grille with sack opener | 13. Mortar pressure gauge |
| 5. Hopper | 14. Rubber mixing section |
| 6. Air compressor K2N | 15. Castor |
| 7. Carrying handle | 16. Power connection at control cabinet |
| 8. Double stop castor | 17. Control cabinet |
| 9. Water sampling valve | 18. Locking lever |

9 Description of assemblies

The mixing pump PFT G 4 X consists of the following main components:

9.1 Hopper



- Hopper with frame and protective grille

Fig. 6: Assembly unit hopper

9.2 Control cabinet item number 00 25 46 66

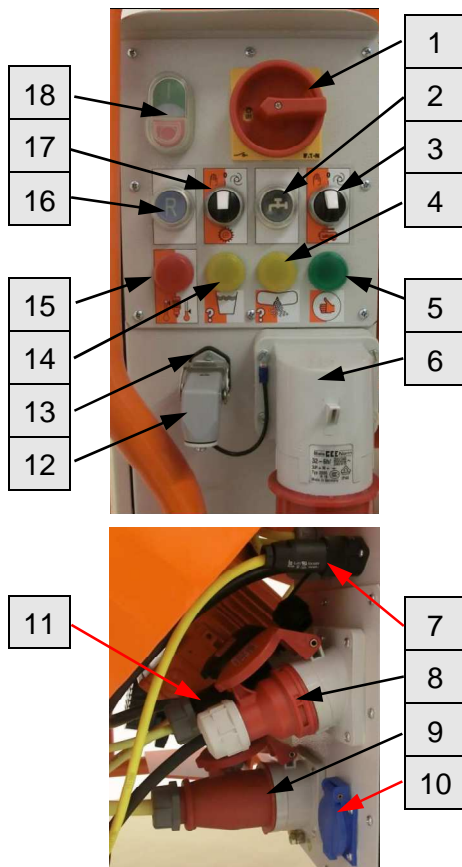

- Control cabinet
1. Master switch is also emergency-stop switch
 2. Push button water inlet
 3. Selector switch water pump manual-0-automatic
 4. Yellow pilot lamp, no material
 5. Green pilot lamp, lights up only if the supply is ok and if the inclination switch has not been triggered
 6. Main terminal 32A.
 7. Connection for fill level sensor in hopper
 8. CEE socket outlet 4x16A, for air compressor
 9. CEE socket outlet 7x16A, for pump motor
 10. Schuko socket outlet 230V, continuous current
 11. CEE socket outlet 4x16A, controlled for water pump
 12. Dummy connector for remote-controlled power socket
 13. Remote control socket
 14. Yellow pilot lamp, no water
 15. Red pilot lamp, motor protection switch was triggered
 16. Push button reverse direction of rotation
 17. Selector switch star wheel
 18. Operating button machine "ON" / "OFF" (control voltage)

Fig. 7: Assembly unit control cabinet

9.3 Mixing tube with motor and pump

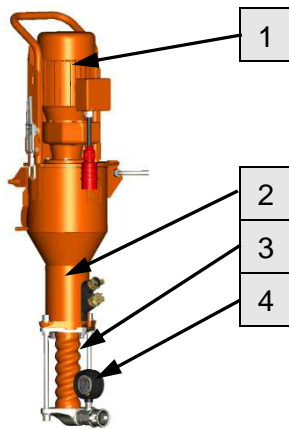

1. Pump motor 5.5 / 7.5 kW
2. Rubber mixing tube with adaptable flange
3. Pump unit D6-3 / D6-4
4. Mortar pressure gauge

Fig. 8: Assembly unit mixing tube with motor

9.4 Water tap

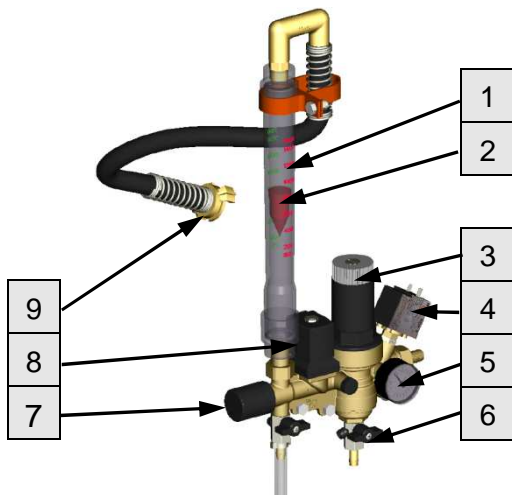

1. Water flow meter 150-1500l/h
2. The floater shows the set water factor on the scale of the plastic tube
3. The water pressure can be adjusted at the pressure reducer
4. Pressure switch water shuts down the machine in case the water pressure is too low
5. Pressure gauge water / operating pressure
6. Drain tap for frost protection
7. The required water factor is set at the needle valve
8. Solenoid valve
9. Water to mixing tube

Fig. 9: Water tap assembly

9.5 Air compressor K2 N with pressure switch-off



- Air compressor K2 N with pressure switch-off

Fig. 10: Air compressor

10 Connections

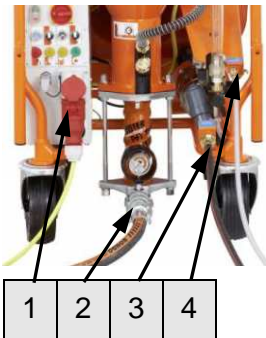

1. Main terminal
2. Connections material hoses
3. Connection water supply from mains
4. Connection air to spray gun

Fig. 11: Connections

11 Operating modes

11.1 Selector switch star wheel



Fig. 12: Operating modes star wheel

The star wheel can be operated in three operating modes:

Selector switch position “0”:

The star wheel is switched off and thus the material supply to the mixing section is interrupted, e.g. for cleaning the mixing section using the cleaning shaft or carrying out a pressure test of the pump.

Selector switch right:

The star wheel is running in sync with the mixing pump motor and is switched on and off using the air control or remote control.

Selector switch left:

The star wheel is running in continuous mode, independent from the air control. In this position material can be added to the mixing section if the pump is deactivated.

11.2 Selector switch pressure booster pump



Fig. 13: Operating modes water pump

The pressure booster pump can be operated in three different operating modes:

Selector switch position “0”:

Water pump is switched off, e.g. if the water pressure is continuously at 2.5 bar.

Selector switch right:

Water pump is running in sync with the mixing pump (automatic mode).

Selector switch left:

The water pump runs continuously in position “manual” (e.g. for cleaning the hoses).

12 Accessories



Fig. 14: Injection hood

PFT injection hood E1 for G 4 (article number 20 60 02 13).

The PFT injection hood is used for feeding dry material to the mixing pump using the PFT SILOMAT pneumatic conveying system.



Fig. 15: Delivery hood

PFT delivery hood with off-load operation protection for G 4 (article number 20 60 05 00)

The PFT delivery hood is used for feeding dry material to the mixing pump PFT G 4 directly from the silo / container. In case of an empty alarm in the hopper, the mixing pump is switched off via the remote control socket.



Fig. 16: ROTOMIX

ROTOMIX D-pumps cmpl. with 35 coupling (article number 20 11 80 00)

Remixer for better decomposition and mixing of the material. Direct drive via tang of the rotor. Contents approx. 1.2 l



Fig. 17: ROTOQUIRL

ROTOQUIRL II cmpl. with 35 coupling (article number 20 11 84 00)

Remixer for better decomposition and mixing of the material. Direct drive via tang of the rotor. Contents approx. 4.2 l



Fig. 18: Water hose/air hose

Water hose/air hose 3/4" x 40m with Geka couplings (article number 20 21 21 00)



Fig. 19: Remote control cable

Remote control cable 25m complete with ON/OFF switch and pilot lamp (article number 20 45 69 29)



Fig. 20: Power cable

Power cable 5 x 4 mm² 25m with CEE plug and coupling 5 x 32A 6h red (article number 20 42 39 20)

Further accessories can be found at www.pft.eu

Intended use Control panel

13 Intended use Control panel

13.1 Intended purpose control panel

The tool is conceptualised and designed exclusively for the purpose of use specified here.



Scope of application:

Primary use for water and neutral, non-adhesive liquids. Also suitable for air and neutral non-flammable gases.

Maximum operating pressure (inlet pressure) 16 bar.

Outlet pressure infinitely adjustable from 1.5 to 6 bar.

Smallest possible inlet pressure 2.5 bar.

Minimum pressure drop (inlet pressure/outlet pressure) 1 bar.

Maximum media and ambient temperature 75°C.

Assembly position as desired, preferable vertical.

13.2 Intended purpose solenoid valve



Scope of application:

Solenoid valves for liquid and gaseous media, aggressive or neutral, can be used different temperature and pressure ranges

Type 6213 is a 2/2 way solenoid valve with straight passage, normally closed, with a permanently coupled membrane system. It operates from 0 bar and can be used universally for liquids. A minimum pressure differential of 0.5 bar is required for the valve to fully open.

13.3 Intended purpose flow meter



Scope of application:

The flow meter is used for the volume measurement of transparent liquid and gaseous flows in closed pipelines. Optionally the devices can be used for flow monitoring.



WARNING!

Danger due to improper use!

Any case of use beyond the specified purpose of use and/ or any other sort of use of the tool can lead to dangerous situations.

Therefore:

- Use the tool only for the purpose specified.
- Always adhere to the usage directives of the material manufacturer.
- Strictly follow all instructions in this operating manual.

Claims of any kind due to damage caused by improper use will not be entertained.

The operator of the tool is alone responsible for any damage arising from improper use.

14 Intended use air compressor

14.1 Intended purpose air compressor

The tool is conceptualised and designed exclusively for the purpose of use specified here.



Attention!

The air compressor is intended exclusively for the generation of compressed air and is to be used with connected implement. Any other use or use beyond what is specified, such as with freely accessible and/or open hoses and pipelines, is deemed to be not for the intended purpose. Connected implements or components are to be designed for the maximum generated pressure of 5.5 bar.

The air compressor is to be used only in technically perfect condition as well as for its intended use and while taking into account the safety and hazard information in the operating instructions!

Particularly malfunctions that may compromise safety have to be eliminated immediately prior to putting the compressor back into operation.



14.2 Safety systems air compressor



WARNING!
Danger of death due to non-functioning safety equipment!

Safety equipment ensure highest level of safety in operation. Even if work processes become a little more complicated due to safety equipment, they must never be decommissioned. The safety is guaranteed only with intact safety equipment.

Therefore:

- Before starting work, check if the safety equipment is functioning properly and has been correctly installed.
- Use safety equipment at all times.
- Do not obstruct access to safety systems such as emergency stop buttons, pull cords etc.

14.3 General positioning of the air compressor

The air compressor complies with the national and international safety regulations and can therefore also be used in damp rooms and/or outdoors. Areas with clean and dry air should be preferred. Ensure that the device can freely suck in the air. This applies in particular if an installation is intended.

The air compressor should only be set up in such a way that no dangerous additives, such as solvents, vapours, dusts or other harmful substances can be sucked in. The device should be positioned only in rooms where the hazard of a potentially explosive atmosphere is not given.

14.4 Hot surface of the air compressor

General information



WARNING!
Danger of injury due to hot surface!

During operation the compressor can reach a surface temperature of up to 100 °C. Therefore it has to be ensured that the device does not get into contact with bare body parts during use as well as for some time after use, in relation to the heating temperature.



15 Description G 4 X SUPER / G 4 X XL

15.1 Functional principle G 4 X SUPER / G 4 X XL



Fig. 21: Description

The dry section to accommodate the ready-mixed mortar is separated from the mixing and pumping section. The dry mortar is thrown into the mixing chamber via the inclined star wheel. The PFT G 4 X can be started and refilled at any time. The star wheel is powered separately and can be quickly disassembled using a central locking mechanism.

15.2 Functional description G 4 X SUPER / G 4 X XL



Fig. 22: Functional description

The new mixing pump G 4 X Standard with 400V three-phase drive was specially developed for pumping, spraying and applying of dry mortar, pasty materials for machine use and much more up to 3 mm grain size.

The pump output can be adjusted by means of a quick pump change depending on the requirements.

The machine can be filled with bagged material as well as directly from a silo/container by means of delivery hood or injection hood and PFT SILOMAT installation.

15.3 Fields of application

For pumpable pre-mixed dry mortar such as:

- gypsum plasters
- lime/gypsum plasters
- cement plasters
- lime plasters
- fango material
- insulation plasters
- filling plasters
- armour and gluing mortar
- floor screed
- masonry mortar
- and much more

16 Material:

16.1 Flowability / Flow characteristics



NOTE!

- The pump unit D6-3 can be used up to 30 bar operating pressure.
- The pump unit D6-4 can be used up to 40 bar operating pressure.
- The possible conveying distance depends mainly on the flowability of the material.
- If 30 or 40 bar operating pressure are exceeded the mortar hose length has to be reduced.
- In order to avoid machine faults and increased wear of the pump motor, pump shaft and the pump itself, only original PFT spare parts such as
 - PFT rotors
 - PFT stators
 - PFT agitators
 - PFT mortar hoses must be used.
- These are compatible with each other and form a constructive unit with the machine.
- Non-compliance does not only cause loss of guarantee, but also bad mortar quality is to be expected.

17 Mortar pressure gauge



Caution!

The use of a mortar pressure gauge is recommended for safety-related reasons.



Fig. 23: Mortar pressure gauge

PFT mortar pressure gauge

Some advantages of the mortar pressure gauge:

- Exact adjustment of the correct mortar consistency.
- Constant control of the right conveying pressure.
- Early detection of clogging or overload of the pump motor.
- Relieving pressure.
- Is a major contribution to the safety of the operators.
- Long service life of the PFT pump parts.

18 Safety rules



Caution!

Observe the regional safety rules for mortar conveyors and mortar guns!



19 Transport, packing and storage

19.1 Safety instructions for transport

Improper transport



ATTENTION!

Damage from improper transport!

Improper transport may cause substantial property damage.

Therefore:

- When unloading the packages on delivery as well as transport within the company pay attention and observe the symbols and instruction on the package.
- Use only the specified anchorage points.
- Remove packaging only shortly before the assembly.

Suspended loads



WARNING!

Danger to life from suspended loads!

When lifting heavy loads there is danger to life from falling parts or uncontrolled swinging parts.

Therefore:

- Never step under suspended loads.
- Observe the instructions regarding the provided anchorage points.
- Do not fix at projecting machine parts or eyelets of attached components and ensure safe fit of the sling gear.
- Use only approved lifting gear and sling gear with sufficient lifting capacity.

19.2 Transport inspection

On receipt check the delivery immediately for completeness and transport damage.

In case of externally visible transport damage, proceed as follows:

- Do not accept the delivery or under reserve only.
- Note the extent of damage on the transport documentation or on the delivery note of the carrier.
- Initiate complaint process.



NOTE!

Report any defect as soon as it is detected. Claims for damages can be asserted only within the valid warranty period.

19.3 Transport

Anchor points

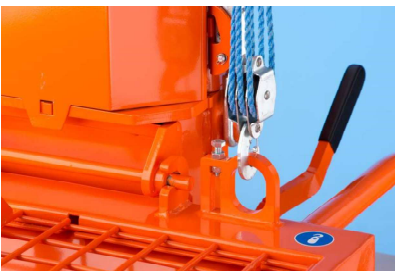

Fig. 24: Anchor points

Anchor the machine at the anchor points for transport by crane.

Observe the following conditions:

- The crane and lifting equipment have to be designed for the weight of the packages.
- The operator has to be authorised to operate the crane.

Attachment:

1. Anchor hooks in accordance with to both crane hooks.
2. Ensure that the package is straight, possibly observe eccentric centre of gravity.

19.4 Transport with van



Fig. 25: Transport

1. Remove the water hose form the mixing tube.
2. Loosen the locking lever and lift the mixing tube.
3. Insert the hook of the protective grille at the motor protection handle.
4. Lock the castors of the machine.



DANGER!

Danger of injury by unsecured loads!

In case of road transport, all persons involved in the loading process are responsible for the proper securing of the load. The responsible driver is responsible for the operational loading.



Transport of already running machine



DANGER! **Risk of injury from discharged mortar!**

Injuries to face and eyes can occur.

Therefore:

- Before opening the couplings ensure that there is no more pressure on the hoses (observe display at mortar pressure gauge).

1. Carry out the following steps before beginning the transport:
2. First unplug the mains cable.
3. Unplug all other cable connections.
4. Remove water supply line.
5. Remove loose parts, e.g. compressor prior to transport by crane.
6. Start transport.

19.5 Transport in individual parts



Fig. 26: Transport

1. Disassemble the machine in the units mixing tube and hopper for easier transport. These can be transported separately.

20 Packaging

For packaging

The individual packages have to be packed in accordance with the transport conditions to be expected. Only environmentally-friendly materials were used for the packaging.

The packaging should protect the individual components until the assembly from transport damage, corrosion and other damage. Therefore do not destroy the packaging and remove only shortly before the assembly.

Handling packaging materials

If no agreement for the recovery of the packaging has been made, separate materials according to type and size and reuse or recycle.



ATTENTION!

Environmental damage due to wrong disposal!

Packaging materials are valuable raw materials and in many cases they can be reused or reconditioned and recycled.

Therefore:

- Dispose of packaging materials in an environmentally-friendly way.
- Observe the applicable local disposal regulations. If required hand over the disposal to a specialist.

21 Operation

21.1 Safety

Personal protective equipment

The following protective equipment has to be worn for all operative work:

- Protective clothing
- Protective goggles
- Protective gloves
- Safety shoes
- Hearing protection



NOTE!

Further protective equipment that is to be worn when effective particular jobs will be pointed out separately in the warning instructions of this chapter.

Basic information



WARNING!
Danger of injury due to incorrect operation!

Improper operation may lead to serious damage to persons or property.

Therefore:

- Carry out all operating steps according to the instructions in this user manual.
- Prior to starting your work, ensure that all covers and protection devices are installed and work as intended.
- Never deactivate protection devices during operation.
- Ensure order and cleanliness in the work area! Loose components and tools on top of another or lying about pose potential accident risks.
- Increased noise level may cause permanent hearing deficiencies. At close range of the machine 95 dB(A) can be exceeded due to operational conditions. Close range is a distance of less than 5 metres to the machine.

22 Safety system



Fig. 27: Safety system

Inclination switch (1) in the terminal box of the geared motor.

- The inclination switch triggers as soon as the quick closure is opened and the geared motor is tilted on the side.
- If the machine is on rough terrain, the inclined position of the machine can also trigger the inclination switch.

23 System monitoring

23.1 Idle-running protection



Fig. 28: Fill level sensor

As soon as no material touches the fill level sensor anymore, the machine switches off. This prevents the hopper from emptying and a consistent mortar consistency at the spray gun is ensured.

Preparing the machine

24 Preparing the machine

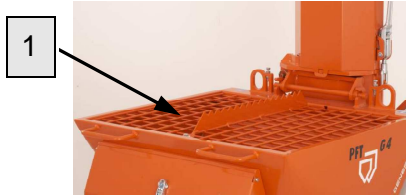

Fig. 29: Grille cover



Fig. 30: Lockable castor

Prior to operating the machine carry out the following steps for preparing the machine:



DANGER!
Running star wheel!

Risk of injury when reaching into the running star wheel.

- During machine preparation and operation the grille cover (1) must not be removed.
- Never reach into the running machine.

1. Lock the lockable castor prior to operating the machine.
2. Put up the machine on a stable, even surface and secure against unwanted movements:
 - Neither tilts nor rolls off the machine.
 - Put up the machine in such a way that it cannot be hit by falling objects.
 - The operating elements have to be freely accessible.
 - Maintain a clearance of approx. 1.5 metres around the machine.

25 Connecting the power supply 400 V

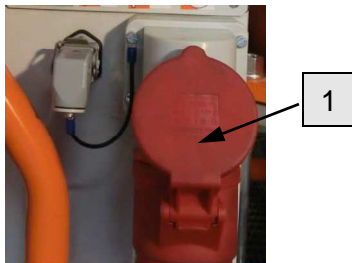
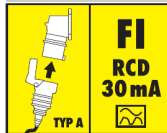

Fig. 31: Power supply 400 V

1. Connect machine (1) to three-phase network 400 V.



DANGER!
Danger of death from electric current!

The connection line has to be fused properly:

Connect the machine only to a power source with permissible RCCB (30 mA) RCD (residual current operated device) type A.



Connecting the water supply

25.1 Check the individual connectors

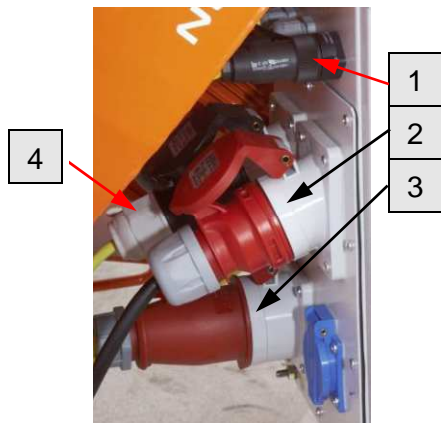

Fig. 32: Power connections

- Check connections of fill level sensor (1).



NOTE!

The sensor prevents the hopper from emptying completely. As soon as no material touches the fill level sensor anymore, the machine switches off.

The machine can also be operated without fill level sensor.

The sensor is without function if the plug of the fill level sensor is pulled.

- Check connection of air compressor (2).
- Check connection of pump motor (3).
- Check connection of booster pump (4).



WARNING!

Danger to life from rotating parts!

Improper operation may lead to serious damage to persons or property.

- The respective drive (motors) must be operated only with the control cabinet of the machine.

26 Connecting the water supply

26.1 Close water draining cocks

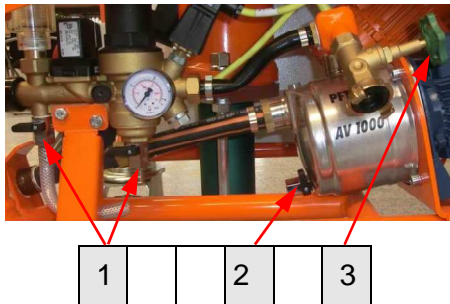

Fig. 33: Water draining cocks

1. Close the water draining cocks (1) at the water fitting.
2. Connect the water draining cock (2) to the booster pump.
3. Close the water sampling valve (3).

Connecting the water supply

26.2 Connecting the water supply

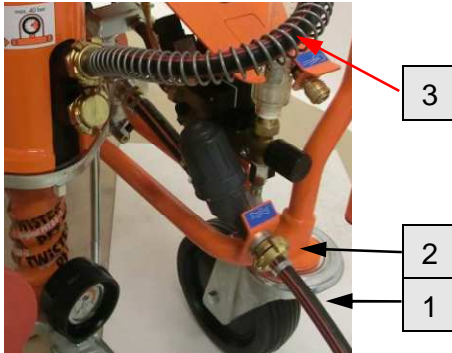

Fig. 34: Connecting the water

1. Clean the water hose (1) from the water supply and bleed.
2. Connect the water hose (1) to the water inlet (2).

NOTE!



Use only clean water free of solids. The minimum pressure is 2.5 bar when the machine is running.

Pay attention to the Drinking Water Ordinance in part 1.



NOTE!

Never let the pump run dry as this reduces the service life of the pump.

3. Remove the water hose (3) from the mixing tube.
4. Open the water tap from the water supply.

26.3 Connection of water from water tank



Fig. 35: Filter screen

NOTE!



When working from the water tank, the strainer with filter screen (article number 00136619) has to be positioned upstream (bleed booster pump).



NOTE!

Never let the booster pump run dry as this reduces the service life of the pump significantly.

27 Switching on the G 4 X

27.1 Putting the machine into operation

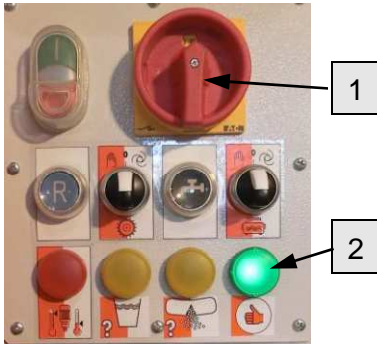

1. Turn main switch (1) to position "I".
2. Green pilot lamp (2) lights up.



NOTE!

The green pilot lamp (2) lights up only if the supply is ok and if the inclination switch has not been triggered

Fig. 36: Switching on

27.2 Set water quantity

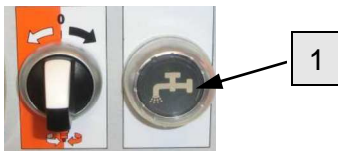

1. Press the water supply button (1) to adjust the water quantity.

Fig. 37: Water supply button

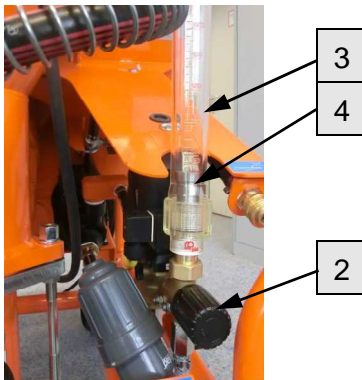

2. At the same time adjust the expected amount of water required at the needle valve (2).
3. The water flow can be seen at the inspection glass (3) of the water flow meter and the level of the floater (4).



NOTE!

The specifications of the material manufacturer are to be observed here, e.g. Knauf MR75 water consumption approx. 650l/h



NOTE!

Any interruption of the spray operation results in a slight irregularity in the consistency of the material. This irregularity normalises by itself as soon as the machine has been working for a short while. Therefore it is important not to change the water quantity for each irregularity. Wait until the consistency of the material has set again.

Fig. 38: Adjust amount of water

Mortar pressure gauge

27.3 Soaking of the mixing section

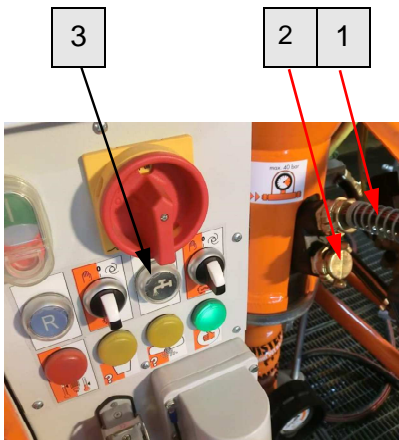

Fig. 39: Soaking



NOTE!

As a rule, the pump has to be soaked. The soaking process permits an easier start-up of the pump.

1. Connect the water hose (1) of the water fitting at the mixing tube.
2. Remove the blind cover (2) from the lower water nozzle.
3. Press the water supply button (3).
4. Release the water supply button (3) as soon as water emerges from the lower water nozzle.
5. Screw the blind cover (2) back on the lower water nozzle.

28 Mortar pressure gauge



Fig. 40: Mortar pressure gauge



DANGER!

Operating pressure too high!

Machine parts can open in an uncontrolled manner and injure the operator.

- Do not operate the machine without mortar pressure gauge.
- Use only mortar hoses with a permissible operating pressure of at least 40 bar.
- The burst pressure of the mortar hose must reach at least 2.5 times the value of the operating pressure.

29 Hazardous dusts



Fig. 41: Dust protection



Warning!

In the long term, inhaled dust can lead to lung damage or have other adverse health effects.



NOTE!

The machine operator or the person working in the dusty area always has to wear a dust protection mask when filling the machine!

The rules of the Committee on Dangerous Substances (AGS) can be found under Technical Rules for Dangerous Substances (TRGS 559).



Feeding dry material to the machine

29.1 Anti-dust unit G 4



Fig. 42: Anti-dust unit

Anti-dust unit G 4 X SUPER article number 00 43 24 13.

Anti-dust unit G 4 X XL article number 00 43 24 18.

Consisting of:

1. Anti-dust grille with suction frame
2. Industrial vacuum cleaner.
3. Deflector plate.
4. Pipe clamp with rubber profile, edge protection and sealing profile.

30 Feeding dry material to the machine



Fig. 43: Bagged goods

Depending on the equipment, the machine can be fed with bagged goods, with the delivery hood or the injection hood.

- Feeding with bagged goods:



DANGER!
Risk of injury at the sack opener!

The sharp edges of the sack opener pose a risk of injury.

- Wear safety gloves.

Feeding with injection hood:

- Accessory article number 20 60 02 13
- Put the delivery hood instead of the grille cover.



DANGER!
Risk of injury at the star wheel!

Do not open the machine during pneumatic conveying. Before opening, turn off the master switch and interrupt the power supply.



NOTE!

First feed material to the mixing pump G 4 X. Pull the dummy connector or switch off the machine using pressure control air. Start your work only when the level sensor indicates full.



Fig. 44: Injection hood

Monitoring the machine



Fig. 45: Delivery hood

Feeding with delivery hood:

- Accessory article number 20 60 05 00
- Put the delivery hood instead of the grille cover.



DANGER!
Risk of injury at the star wheel!

Do not open the delivery hood during the operation of the machine. Before opening, turn off the master switch and interrupt the power supply.

31 Monitoring the machine



DANGER!
Access by unauthorised persons!

The machine must be operated only if monitored.

32 Putting the machine into operation

32.1 Check consistency of mortar



Fig. 46: Consistency test tube

1. Connect consistency test tube at the mortar pressure gauge.
2. Place a bucket or pan under the consistency test tube.

Article number: 20104301 Consistency test tube 25m piece

32.2 Start the machine in a “flying” mode

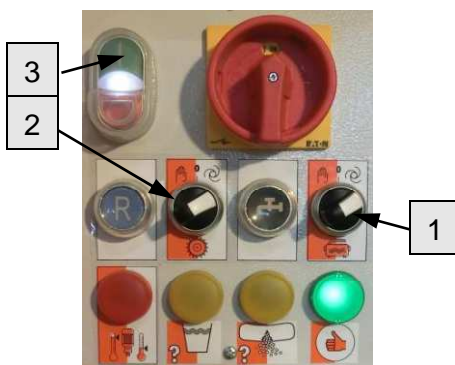

Fig. 47: Switching on

1. Turn the selector switch (1) of the booster pump clockwise.
2. Turn the selector switch (2) for the star wheel to the right.
3. Switch on the machine, press the green push button (3) control voltage “ON”.

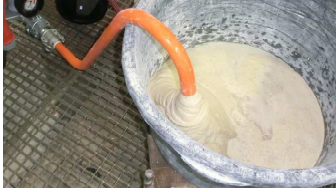

Fig. 48: Consistency of mortar

4. Check consistency of mortar.

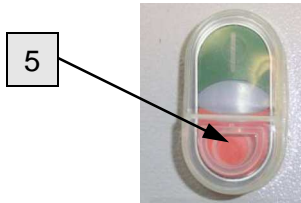

Fig. 49: Switching off

5. Switch off the machine, press the red push button (5) control voltage "OFF".
6. Remove consistency test tube and clean it.

33 Mortar hoses

33.1 Prepare mortar hoses

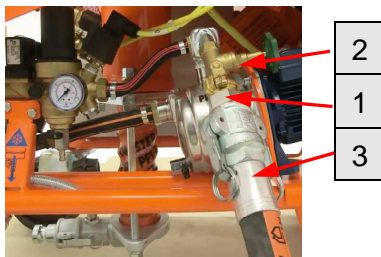

Fig. 50: Prepare mortar hose

1. Connect the cleaner coupling (1) at the water extraction valve (2).
2. Connect mortar hose (3) and water.
3. More mortar hose and cleaner coupling again and separate.
4. Remove all the water from the mortar hose.
5. Pre-lubricate the mortar hose with about two litres of wallpaper paste.
6. The wallpaper paste is mixed through the mortar hose with the first mixing.



DANGER!

Never loosen the hose couplings as long as there is pressure on the mortar hoses (check mortar pressure gauge)! The mix could burst out under pressure and result in serious injuries, especially injuries to the eyes.

Torn off hoses can beat about and injure bystanders!

Compressed air supply

33.2 Connect mortar hose

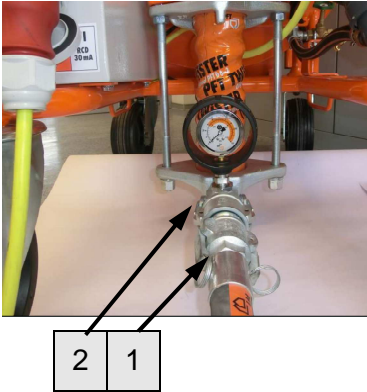

Fig. 51: Connect mortar hose

1. Connect mortar hose (1) to the pressure flange (2).

NOTE!



Ensure clean and correct connection and tightness of the couplings! Dirty couplings and rubber seals are not watertight, and water might leak under pressure inevitably leading to blockages.

2. Lay mortar hoses in large radius so that no kinks form in the hoses.
3. Attach risers carefully in order to prevent them from tearing off under their own weight.

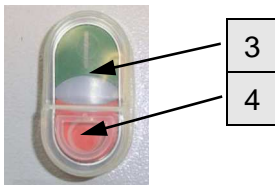

Fig. 52: Switching on

4. Switch on the machine, press the green push button (3) control voltage "ON".
5. As soon as mortar emerges from the end of the mortar hose, press the red push button (4) control voltage "OFF".

34 Compressed air supply

34.1 Connect air hose



Fig. 53: Connect air hose

1. Connect compressed air hose (1) at the air fitting.



DANGER!

Never loosen the hose couplings as long as the compressed air hose is not depressurised.

34.2 Connecting the spraying gun

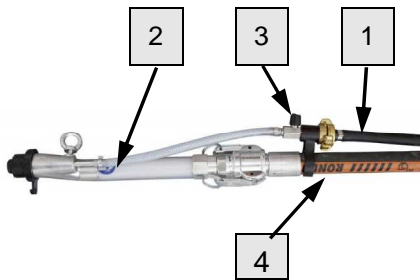

1. Connect the compressed air hose (1) at the spraying gun (2).
2. Ensure that the air tap (3) is connected to the spraying gun.
3. Connect the spraying gun (2) at the mortar hose (4).

Fig. 54: Spraying gun

34.3 Switch on air compressor



1. Switch on the air compressor using the black switch (1).
2. As soon as the air compressor has built up pressure in the pipeline system, it switches off using the pressure switch-off.

Fig. 55: Air compressor

35 Apply mortar



DANGER!
Risk of injury from discharged mortar!

Discharged mortar may lead to injuries to eyes and face.

- Never look into the spraying device.
- Always wear protective goggles.
- Always position yourself in such a way that you are not hit by the mortar being discharged.



NOTE!

The possible conveying distance depends mainly on the flowability of the mortar. Heavy, sharp-edged mortar has poor flow characteristics. Runny materials have good flow characteristics.

If 30 / 40 bar operating pressure are exceeded, thicker mortar hoses have to be used.

35.1 Open the air tap at the spraying gun

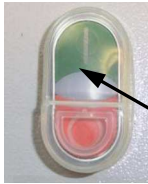

Fig. 56: Switching on

1



Fig. 57: Opening the air tap

2

1. Switch on the machine, press the green push button (1) control voltage "ON".
2. Aim the spray gun at the wall to be plastered.
3. Ensure that nobody is in the discharge area of the mortar.
4. Open the air tap (2) at the spraying gun.
5. The machine will start-up automatically via the pressure switch-off and the mortar emerges.



NOTE!

The correct mortar consistency is reached, if the material mixes on the surface to be sprayed (we recommend application on wall surfaces from top to bottom). If the water quantity is too little even mixing and spraying is no longer guaranteed; blockages may form inside the hose and high wear of the pump parts will become an issue.



NOTE!

It is also possible to operate the machine without compressed air, e.g. for pumping screed. Switch off the compressor at the red switch.

Connect the remote control (see chapter 36 remote control) and use it to switch on/switch off the machine.

35.2 Interruption of work



NOTE!

Always observe the setting time of the material to be processed:

Clean the system and mortar hoses depending on the setting time of the material and the length of the interruption (pay attention to outside temperature).

The guidelines of the material manufacturers have to be observed regarding breaks.

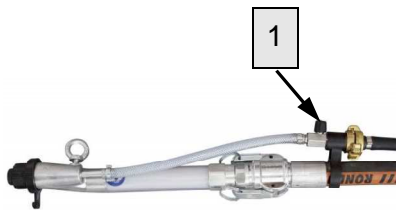

Fig. 58: Closing the air tap

1. Close the air tap (1) if you interrupt your work for a short while.
2. The machine stops.
3. Once you open the air tap (1), the machine will start-up again.

35.3 In case of longer interruption of work/break

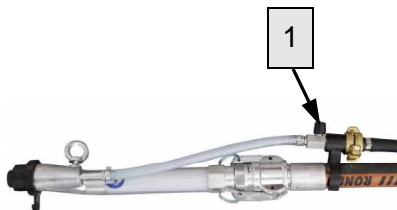

Fig. 59: Closing the air tap

1. Close air tap (1).
2. Switch off the machine, press the red push button (2) control voltage "OFF".

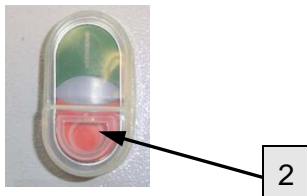

Fig. 60: Switching off

35.4 Switch off air compressor



Fig. 61: Air compressor

1. Switch off the air compressor at the red switch (1).
2. Open the air tap at the spraying gun.



DANGER!
Risk of injury from discharged mortar!

Discharged mortar may lead to injuries to eyes and face.

➤ Attention, residual pressure.

36 Remote control

36.1 Working with the remote control

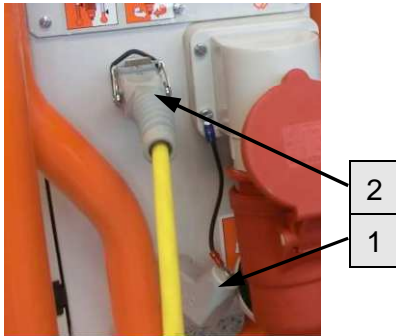

1. Remove dummy connector (1) from control cabinet.
2. Connect remote control (2).
3. The G 4 X can be switched on or off using the remote control.

Fig. 62: Remote control

37 Stopping in case of emergency Emergency-stop switch

37.1 Emergency-stop switch

Stopping in case of emergency



Fig. 63: Stopping

In dangerous situation machine movements have to be stopped as quickly as possible, and the power supply has to be disconnected.

In case of danger proceed as follows:

1. Turn main switch (0) to position "0".
2. Secure the main switch against start-up using a lock.
3. Inform responsible person at the operational site.
4. If necessary call for medical assistance and fire brigade.
5. Recover persons from the danger zone, initiate First Aid measures.
6. Keep access routes free for emergency vehicles.
7. If the severity of the emergency permits inform the competent authorities.
8. Assign specialised personnel with the troubleshooting.

After the rescue operations



WARNING!

Danger to life from premature reactivation!

On reactivation there is danger to life for all persons in the danger zone.

- Before reactivation ensure that there are no persons in the danger zone anymore.

9. Check the system before reactivation and ensure that all safety equipment is installed and functional.



38 Measures in case of power cut

38.1 Relieve mortar pressure

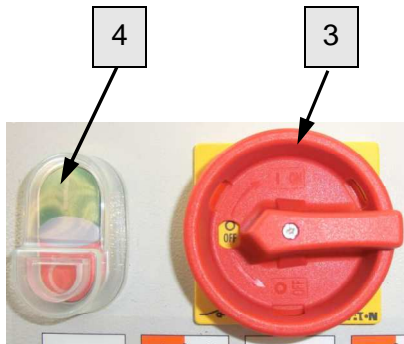

Fig. 64: Power failure

1. Close the air tap at the spraying gun.
2. Turn main switch (1) to position "0".
3. Switch off the air compressor at the red switch.
4. Let qualified staff check the power supply.

38.2 Relieve mortar pressure



Fig. 65: Check mortar pressure



DANGER!
Overpressure on the machine!

When opening machine parts they can open in an uncontrolled manner and injure the operator.

- Open machine only when the pressure is at "0 bar".



DANGER!
Risk of injury from discharged mortar!

Discharged mortar may lead to injuries to eyes and face.

Therefore:

- Never look into the spraying device.
- Always wear protective goggles.
- Always position yourself in such a way that you are not hit by the mortar being discharged.

1. Open the air tap at the spraying gun.
2. Check the mortar pressure gauge (1) if the mortar pressure has lowered to "0 bar". If required relieve the mortar pressure by lightly loosening the nuts (2). In doing so, cover the work area with film.
3. Firmly tighten the nuts again.

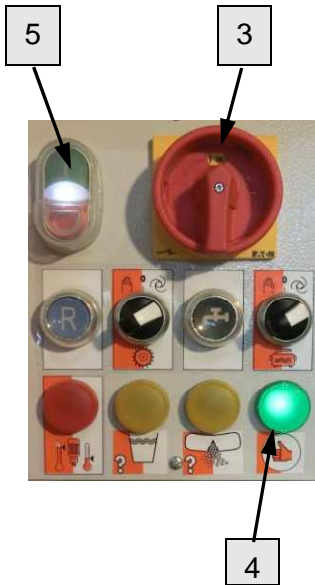

Fig. 66: Restart interlock

i **NOTE!**
The G 4 X is equipped with a restart interlock. In case of a power cut, the system has to be started as follows.

4. Close the air tap at the spraying gun.
5. Turn main switch (3) to position "I".
6. Green pilot lamp (4) lights up.
7. Switch on the air compressor using the black switch.
8. Switch on the machine, press the green push button (5) control voltage "ON".
9. The G 4 X starts again as soon as the air tap at the spray gun is opened again.

i **NOTE!**
In case of a longer power cut, the G 4 X and the material hoses have to be cleaned immediately.

39 Work on troubleshooting

39.1 Reaction in the event of faults

The following strictly applies:

1. In the event of faults presenting immediate danger to persons or property, activate the emergency OFF function immediately.
2. Determine cause for fault.
3. If the rectification of faults requires works in the danger zone, switch off the system and secure against restarting.
4. Inform the manager on site immediately about the fault.
5. Depending on the type of fault commission authorised skilled personnel or rectify the fault yourself.

i **NOTE!**
The following fault table gives information on who is authorised to rectify the fault.



39.2 Fault displays

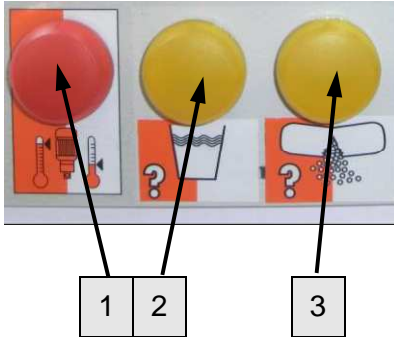

Fig. 67: Fault displays

The following installation indicates faults:

Pos.	Light signal	Description
1	Red pilot lamp	Lights up on motor protection switch fault. Check motor protection switch
2	Yellow pilot lamp	Lights up if there is no water.
3	Yellow pilot lamp	Lights up if material is missing in the hopper.

39.3 Faults

The following chapter describes possible causes for faults and the activities carried out for their rectification. In case faults occur frequently, shorten the maintenance intervals in accordance with the actual load.

In the event of faults that cannot be rectified by means of the following notes, kindly contact the dealer.

39.4 Safety

Protective gear

The following protective equipment has to be worn for all maintenance work:

- Protective clothing.
- Protective goggles, protective gloves, safety shoes, ear protection.

Personnel

- The work for rectification of faults described here can be carried out by the operator, unless marked otherwise.
- Some works must be carried out only by specially trained skilled personnel or exclusively by the manufacturer. Information on this can be found in the description of the individual faults.
- Work on the electrical system must, in principle, be carried out only by electricians.

Work on troubleshooting

39.5 Table of faults

Fault	Possible cause	Solution	Rectification by
Machine does not start water	Water pressure too low	Check water supply, clean strainer screen	Operator/Service engineer
	Pressure gauge shows less than 2.2 bar	Check booster pump	Service engineer
Machine does not start power	Power supply not in order	Repair power supply	Service engineer
	Main switch not activated	Activate main switch	Operator
	RCCB was triggered	Reset RCCB	Service engineer
	Motor protection switch triggered	Turn motor protection switch in control cabinet to position 1	Service engineer
	Operating button "ON" not pressed	Press operating button "ON"	Operator
	Contactors defective	Change contactors	Service engineer
Machine does not start air	Insufficient drop in pressure in the remote control due to blocked air duct or air nozzle pipe	Clean blocked air duct or air nozzle pipe	Operator
	Air safety switch set wrongly	Set air safety switch	Service engineer
	Air compressor not switched on	Switch on air compressor	Operator
Machine does not start material	Too much thickened material in hopper or mixing section	Empty half of the hopper and start again	Operator
	Excessively dry material in pump part	Run the machine in backward mode, otherwise remove pump and clean it	Operator
	Thickened material in material container	Top up material	Operator
Water does not run (flow meter does not show anything)	Solenoid valve (hole in membrane blocked)	Clean solenoid valve	Service engineer
	Solenoid coil defective	Change solenoid coil	Service engineer
	Pressure reducing valve closed	Open pressure reducing valve	Operator
	Water inlet at pump tube blocked	Clean water inlet at pump tube	Operator
	Needle valve closed	Open needle valve	Operator
	Cable to solenoid valve defective	Replace cable to solenoid valve	Service engineer



Work on troubleshooting

Fault	Possible cause	Solution	Rectification by
Pump motor does not start	Pump motor defective	Exchange pump motor	Service engineer
	Connection cable defective	Change connection cable	Service engineer
	Plug or inbuilt socket defective	Change plug or inbuilt socket	Service engineer
	Motor protection switch defective or triggered	Change motor protection switch or reset	Service engineer
Machine stops after a short while	Strainer screen contaminated	Clean or replace strainer	Operator
	Strainer sieve of pressure relieve	Clean or replace strainer	Operator
	Hose connection or water pipe too small	Increase dimensions of hose connection or water pipe	Operator
	Booster pump not switched on	Switch on booster pump	Operator
Machine does not switch off	Air pressure safety switch set incorrectly or defective	Adjust or replace air pressure safety switch	Service engineer
	Air pressure hose defective or seals defective	Replace air pressure hose, replace seals or check compressor	Service engineer
	Air tap at the spraying gun	Replace air tap	Service engineer
	Power provided by compressor is too low.	Check compressor	Service engineer
	Air duct is not connected to the compressor	Connect air duct to the compressor	Operator
Mortar flow "thick-thin"	Too little water	Increase the water quantity by 10% for approx. ½ minute and then turn down slowly	Operator
	Water safety switch set incorrectly or defective	Adjust or replace water safety switch	Service engineer
	Agitator defective; no original PFT agitator	Replace agitator with original PFT agitator	Operator
	Pressure reducer set incorrectly or defective	Adjust or replace pressure reducer	Service engineer
	Rotor worn or defective	Replace rotor	Service engineer
	Stator worn or clamping bracket tightened too little	Replace stator or re-tighten clamping bracket	Service engineer
	Clamping bracket defective (oval)	Replace clamping bracket	Service engineer
	Inner wall of mortar hose defective	Replace mortar hose	Operator
	Rotor too deep in pressure flange	Replace pressure flange	Service engineer
	No original PFT spare parts	Use original PFT spare parts	Service engineer

Work on troubleshooting



Fault	Possible cause	Solution	Rectification by
Mortar flow ceases (air bubbles)	Bad mixture in mixing tube	Add more water	Operator
	Material is clumped and narrows the mixing tube inlet	Add more water or clean agitator or replace	Operator
	Material in mixing tube has become wet	Empty mixing tube, dry it and start again	Operator
	Agitator defective	Replace agitator	Operator
	Driving dog defective	Replace driving dog	Service engineer
During operation water rises in the mixing tube	Backpressure in mortar hose higher than pump pressure	Retighten or replace stator	Service engineer
	Rotor or stator worn	Replace rotor or stator	Service engineer
	Hose is blocked by mortar that is too thick (high pressure by low water factor)	Remove blockage, increase water factor	Service engineer
Red pilot lamp, fault lights up	Overload due to the pump getting blocked with dry material	Run the machine in backward mode, otherwise remove pump and clean it	Service engineer
	Overload due to low water volume	Increase water feed on startup	Operator
	Motor protection switch pump motor triggered	Reactivate protection switch	Service engineer
	Overload due to compacted material in hopper	Clean hopper Reactivate protection switch	Service engineer

39.6 Signs for hose blockages:

- Implementation by operator:
- Blockages can occur in the pressure flange or in the mortar hoses.
- Indications are:
 - rapidly increasing pressure head,
 - blocking of pump,
 - running difficulties or blockage of the pump motor,
 - expansion and turning of the mortar hose,
 - no material discharge at the hose end.



Removal of blockages in the hose

39.7 Causes for this can be:

- Highly worn mortar hoses,
- badly greased mortar hoses,
- residual water in mortar hose,
- clogging of the pressure flange,
- strong tapering at the couplings,
- kink in mortar hose,
- leaks at the couplings,
- badly pumpable and demixed materials.

39.8 Earlier damage to the mortar hose



NOTE!

If in the event of a machine fault by material clogging the pressure in the mortar hose exceeds 60 bar, even only temporarily, replacement of the mortar hose is recommended as there might be damage in the hose that is not externally visible.

40 Removal of blockages in the hose



DANGER!

Danger from discharged material!

Never loosen the hose couplings as long as the pressure head is reduced! Material to be conveyed can be discharged under pressure and cause injuries particularly to the eyes.

Persons commissioned with the cleaning of clogged hoses have to wear personal protective equipment (protective goggles, gloves) for safety reasons, and to position themselves in such a way that they cannot be hit by discharged material. Other persons have to clear the area.

Removal of blockages in the hose

40.1 Change the direction of rotation of the mixing pump motor in case of blockages in the hose

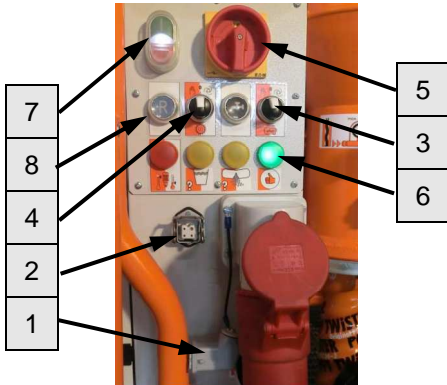

Fig. 68: Change direction of rotation

1. Remove the dummy connector (1) or remote control from the remote control socket (2).
2. Turn the selector switch (3) of the booster pump to position "0".
3. Turn the selector switch (4) of the booster pump to position "0".
4. Switch off the air compressor at the red switch.
5. With the machine switched off, turn the main switch (5) to position "I".
6. Green pilot lamp (6) lights up.
7. Press the green push button (7) control voltage "ON".
8. Move the push button (8) backwards until the pressure at the mortar pressure gauge has dropped to "0 bar".
9. Turn main switch (5) to position "0".

40.2 Blockage does not dislodge

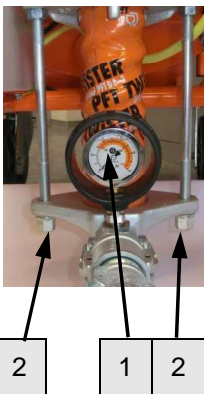

Fig. 69: Mortar pressure gauge



DANGER!

Overpressure on the machine!

When opening machine parts they can open in an uncontrolled manner and injure the operator.

- Open the mortar hoses only when the pressure at the mortar pressure gauge (1) has dropped to "0 bar".

1. Slightly loosen both nuts (2) at the tie rod so that the remaining pressure can escape completely.
2. As soon as the pressure is down to "0 bar", tighten the nuts (2) again.

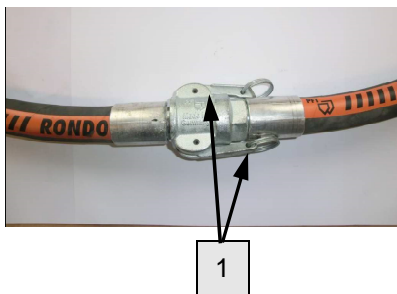

Fig. 70: Loosen coupling



NOTE!

Clean mortar hoses immediately

1. Cover coupling connections with tear-proof film.
2. Loosen cam lever (1) and hose connections.
3. Dislodge the blockage by tapping or shaking at the place where the blockage is located.
4. If required, insert a rinsing hose into the mortar hose and flush out the material (PFT rinsing hose art. no. 00113856).



40.3 Switch the machine back on after the blockage has been removed

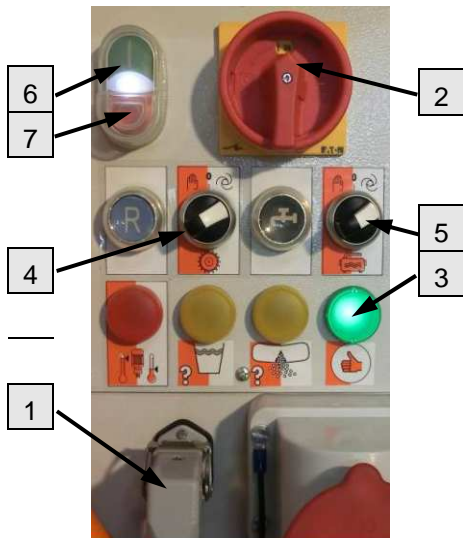

Fig. 71: Switching on

1. Insert dummy connector (1) or remote control.
2. Turn main switch (2) to position "I".
3. Green pilot lamp (3) lights up.
4. Turn the selector switch (4) of the star wheel motor clockwise.
5. Turn the selector switch (5) of the booster pump clockwise.
6. Press the green push button (6) control voltage "ON".
7. Let the machine run for a short while without mortar hoses.
8. As soon as mortar emerges at the pressure flange, press the red push button (7) control voltage "OFF".
9. Apply wallpaper paste to the cleaned mortar hoses and connect to the machine and spray gun.
10. Switch on the air compressor using the black switch.
11. Press the green push button (6) control voltage "ON", open the air tap at the spraying gun as described in chapter 35.1.

41 Cleaning the machine after work

41.1 Empty the mixing tube



Fig. 72: Switch of star wheel

The machine has to be cleaned daily after work:

1. Shortly before finishing your work turn the selector switch of the star wheel to position "0".
2. The star wheel is switched off and thus the material supply to the mixing section is interrupted, e.g. for cleaning the mixing section using the cleaning shaft or carrying out a pressure test of the pump.



Fig. 73: Switching off

1. As soon as thinner material emerges from the spraying gun, close the ball valve at the spraying gun.
2. Switch the machine off by pressing the red push button (2) control voltage "OFF".
3. Switch off the air compressor at the red switch.
4. Open the air tap at the spraying gun.



DANGER!
Risk of injury from discharged mortar!

Discharged mortar may lead to injuries to eyes and face.

➤ Attention, residual pressure.

Cleaning the machine after work

41.2 Secure against restarting



DANGER!

Danger to life from unauthorised restarting!

When working with the machine there is the risk that the energy supply is switched on without authorisation. This poses a danger to life for the persons in danger area.

- Switch off all power supplies before starting any work and secure against restarting.
- If protective covers have been removed for cleaning purposes, they must be properly put back again without fail after completion.

41.3 Cleaning the G 4 X



ATTENTION!

Water can enter sensitive machine parts!

- Before cleaning the machine cover all openings in which no water must enter for safety and functional reasons (e.g. electric motors and control cabinets).



NOTE!

Do not direct the water jet on electrical parts, such as gear motor or control cabinet.

41.4 Decouple mortar hose

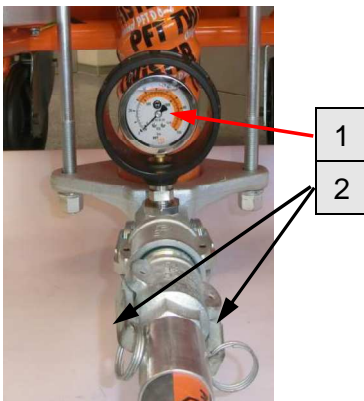

Fig. 74: Mortar pressure to "0" bar.

1. Check at the mortar pressure gauge (1) if the mortar pressure is at "0 bar".



DANGER!

Overpressure on the machine!

When opening machine parts they can open in an uncontrolled manner and injure the operator.

- Open machine only when the pressure is at "0 bar".
2. Loosen the cam lever (2) and decouple the mortar hose from the mortar pressure gauge.

41.5 Clean mortar hose

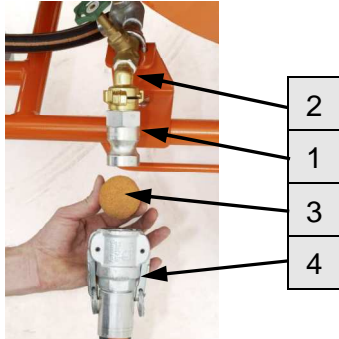

Fig. 75: Clean mortar hose



NOTE!

Mortar hoses and spraying device have to be cleaned immediately after finishing work.

1. Connect the cleaner coupling (1) at the water extraction valve (2).
2. Press the water saturated sponge ball (3) into the mortar hose (4).
3. Connect the mortar hose (4) with the sponge ball to the cleaner coupling (1).

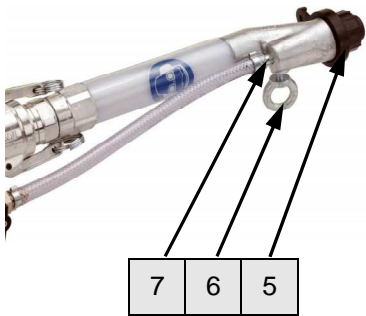

Fig. 76: Air nozzle tube and fine plaster spraying nozzle

4. Remove the fine plaster spraying nozzle (5) from the spraying gun.
5. Loosen the ring screw (6) and pull the air nozzle tube (7) out of the spray head.
6. Water sampling valve pos. 2 fig. 75 until the sponge ball emerges from the fine plaster spraying nozzle. Repeat this process until the hose is clean.
7. In case of different hose diameters, the mortar hoses have to be cleaned separately with the matching sponge balls.
8. In case of strong soiling repeat this process.
9. Clear the air nozzle tube (7) using a round file.
10. Switch on the compressor and purge the air nozzle tube.
11. Reassemble the spraying gun.

41.6 Remove the water hose

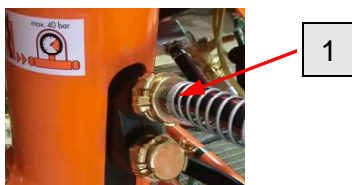
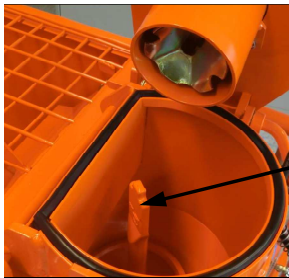

Fig. 77: Water hose

1. Remove the water hose (1) from the mixing tube.

Cleaning the machine after work

41.7 Cleaning the mixing tube



1. Open the quick closure at the motor tilt flange and tilt the motor.
2. Remove the mixing shaft (1) and clean it.

Fig. 78: Open motor tilt flange

41.8 Insert the mixing tube cleaner

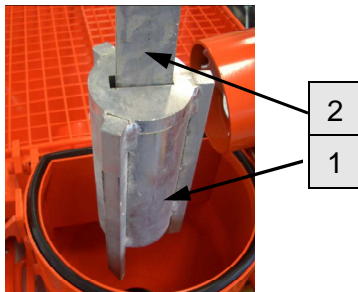

1. Take the mixing tube cleaner (1) and cleaning shaft (2) from the tool box.
2. Insert the mixing tube cleaner (1) into the mixing tube with the scrapers pointing downward.



NOTE!

When inserting the cleaner shaft ensure that the cleaner shaft engages correctly in the drive dog in the head of the rotor and when closing the motor flange.

41.9 Insert the mixing tube cleaner

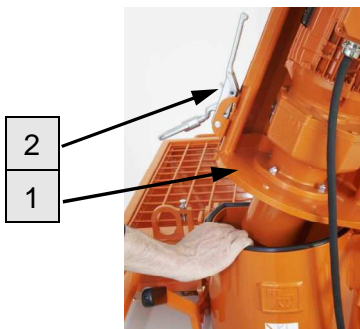

Fig. 80: Close motor tilt flange



DANGER!

Risk of contusion at the motor tilt flange!

There is a risk of contusion when closing the motor tilt flange.

- Do not reach into the clamping area of the motor tilt flange.

1. Close the motor tilt flange (1) and lock using the quick closure (2).



Cleaning the machine after work

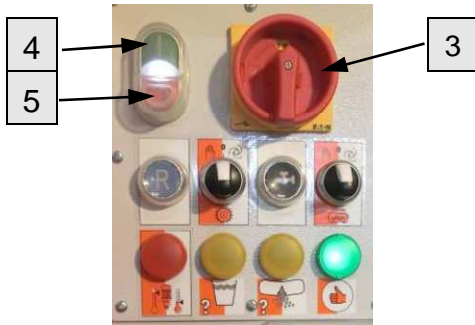

Fig. 81: Cleaning

2. Turn main switch (3) to position "I".
3. Press the green push button (4) control voltage "ON" (4).
4. Let the machine run for about 5 - 10 seconds until the mixing tube has been cleaned.
5. Switch the machine off by pressing the red push button (5) control voltage "OFF".
6. Turn main switch (3) to position "0".

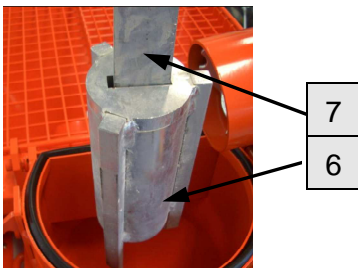

Fig. 82: Remove the mixing tube cleaner

7. Open the quick closure at the motor tilt flange and tilt the motor.
8. Take the mixing tube cleaner (6) and cleaning shaft (7) from the mixing tube.

41.10 Insert agitator

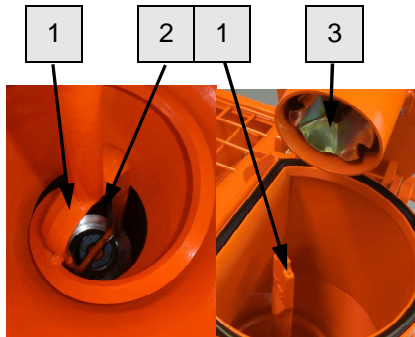

Fig. 83: Insert agitator

1. Insert agitator (1) and ensure correct positioning at the rotor head (2).
2. When closing the tilt flange ensure that the agitator (1) engages properly into the drive dog (3).
3. Close the quick closure at the mixing tube.

41.11 Cleaning the hopper

- The inside of the hopper can be cleaned with a water hose after having been emptied completely.

42 Changing the pump / Cleaning the pump

42.1 Fold up mixing tube

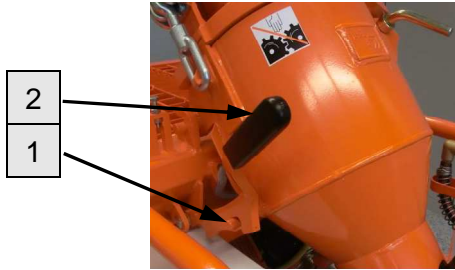

1. Secure the machine against switching on by removing the connection cable.
2. Loosen locking lever (1).



NOTE!

Ensure that the locking lever engages at the mixing tube (2).

Fig. 84: Fold up mixing tube

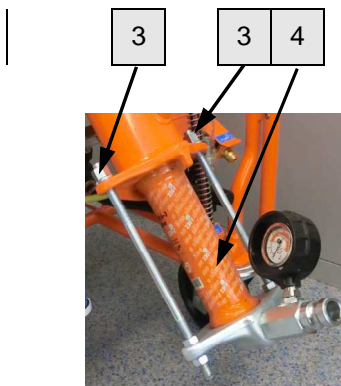

3. Loosen the collar nuts (3).
4. Remove rotor and stator (4).
5. Insert new rotor and stator and tighten collar nuts (3).

Fig. 85: Change pump

43 Switch off G 4 X

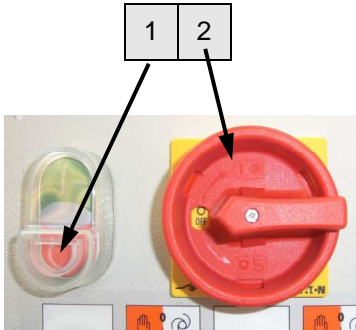

1. Switch off the machine, press the red push button (1) control voltage "OFF".
2. Turn main switch (2) to position "0".

Fig. 86: Switching off

44 Measures in case of risk of frost



ATTENTION!
Damage by frost!

Water that expands inside the machine during frost can cause severe damage.

Therefore:

- The following steps are to be carried out if the machine stands still in case of risk of frost.



1. Close external water supply.
2. Disconnect the water hose (1) from the mixing tube.
3. Open draining cocks (2).
4. Open draining cock (3) at the booster pump.
5. Open water sampling valve (4).

Fig. 87: Risk of frost

Measures in case of risk of frost

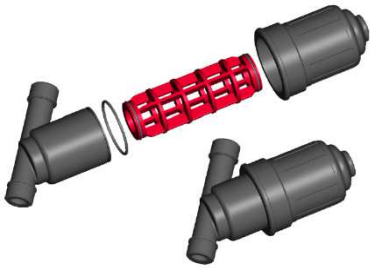

Fig. 88: Strainer

6. Open and empty strainer.

44.1 Blow dry water fitting

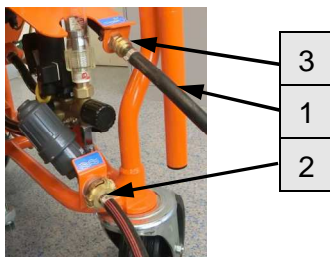

Fig. 89: Dry water fitting

1. Connect water/air hose (1) with EWO and Geka coupling to the water inlet (2) and to the outlet of the air fitting (3).



Fig. 90: Dry water fitting

2. Turn the star wheel (4) of the booster pump to position "0".
3. Turn the selector switch of the booster pump (5) to position "0".
4. Turn main switch (6) to position "I".

44.2 Switch on air compressor



Fig. 91: Air compressor

1. Switch on the air compressor using the black switch (1).
2. Press the water supply button (pos. 7 fig. 90).
3. The water is now blown out of the fitting using compressed air (for approx. 15 seconds).
4. Switch off the compressor at the red switch (1).
5. Turn main switch to position "0".

45 Maintenance

45.1 Safety

Personnel

- The maintenance works described here can be carried out by the operator, unless marked otherwise.
- Some maintenance work must only be carried out by specially trained technical personnel or exclusively by the manufacturer.
- Work on the electrical system must, in principle, be carried out only by electricians.

Basic information



WARNING!

Risk of injury due to improperly carried out maintenance work!

Improper maintenance can lead to severe injuries or considerable property damage.

Therefore:

- Ensure order and safety at the assembly site!
Loose, stacked components or components lying about can cause accidents.
- If components were removed, ensure proper assembly, put back all fastening elements and observe torque indications for screws.

45.2 Remove connection cable

Electrical system



Fig. 92: Remove connection cable



DANGER!

Danger of death from electric current!

There is danger to life if you come in contact with live parts. Activated electrical components can carry out uncontrolled movements and cause serious injuries.

Therefore:

- Switch off the energy supply before starting any work and secure against restarting.
- Disconnect the power supply by removing the connection cable

Secure against restarting



DANGER!
Danger to life from unauthorised restarting!

When working with the tool, there is the risk that the energy supply is switched on without authorisation. This poses a danger to life for the persons in danger area.

Therefore:

- Switch off all power supplies before starting any work and secure against restarting.

45.3 Environmental protection

Observe the following notes on environmental protection when carrying out maintenance works:

- Remove the discharged, exhausted or surplus grease at all greasing points that are lubricated manually and dispose of in accordance with the local applicable regulations.
- Collect replaced oil in suitable containers and dispose of in accordance with the local applicable regulations.

45.4 Maintenance plan

The following paragraphs describe the maintenance works that are required for an ideal and trouble-free operation.

In the event that increased wear is detected during regular checks, the required maintenance intervals have to be shortened according to the actual signs of wear.

Should you have any queries regarding maintenance works and intervals contact the manufacturer, see page 2 for service addresses.



NOTE!

Maintenance is limited to a few checks. Thorough cleaning after use is the most important maintenance.

Interval	Maintenance work	To be carried out by
monthly	Clean/replace filter of compressor.	Service engineer
monthly	Clean/replace plastic sieve in strainer.	Operator
monthly	Clean/replace strainer screen in pressure reducer.	Service engineer

45.5 Maintenance work

45.5.1 Air filter compressor

- Execution by service technician.

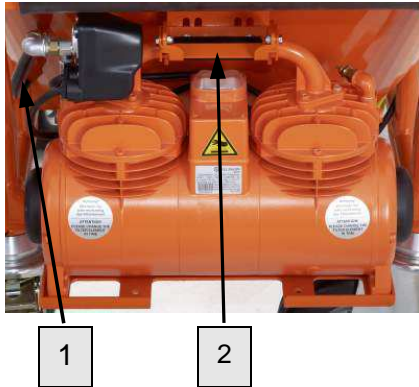

Fig. 93: Air compressor

Remove air compressor from bracket:

1. Loosen air hose (1) from the air compressor.
2. Fold compressor bracket (2) upwards and remove air compressor from bracket.



NOTE!

Take the weight of the air compressor into consideration.

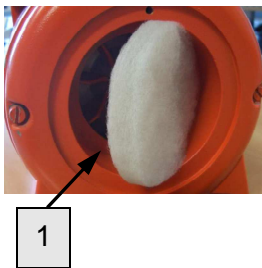

Fig. 94: Filter of the air compressor

3. Remove filter cover.
4. Take out the filter.
5. Blow through the filter from the inside to the outside or tap it.
6. Replace the filter in case of heavy contamination.
7. Insert the filter with the solid side of the filter (1) pointing inwards.

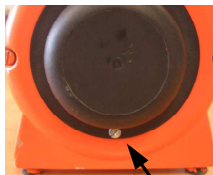

Fig. 95: Opening filter cover

8. Replace filter cover.



NOTE!

Opening of the filter cover is at the bottom.

45.5.2 Plastic screen

■ Implementation by operator.

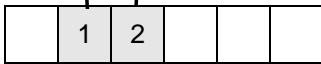

Fig. 96: Cleaning the sieve

1. Remove the closure cap (1) from the strainer.
2. Take out the plastic sieve (2) from the strainer (monthly).
3. Clean the sieve.
4. Replace the sieve in case of heavy contamination.
5. Put the sieve back.
6. Replace the closure cap.

45.5.3 Strainer screen in pressure reducer

a. Execution by service technician.

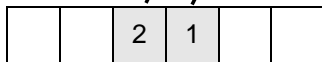
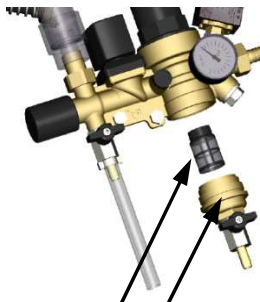

Fig. 97: Strainer screen

2. Remove the closure cap (1) from the pressure reducer.
3. Take out the strainer screen (2) and clean (monthly).
4. Replace the screen in case of heavy contamination.
5. Insert screen and screw on the closure cap.

Screen for pressure reducer: Article number 20156000

45.5.4 Setting value pressure switch water



Fig. 98: Pressure switch water

	Switching on the machine	Switching off the machine
Water	2.2 bar	1.9 bar



45.5.5 Setting value pressure switch air

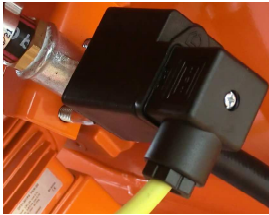

Fig. 99: Pressure switch air

	Switching on the machine	Switching off the machine
Air	0.9 bar	1.2 bar

45.5.6 Setting value pressure switch air compressor

	Switch on air compressor	Switch off air compressor
Compressor	2.5 bar	3.1 bar

45.6 Safety valve air compressor



Fig. 100: Safety valve

- Check, if the safety valve at the air compressor opens against a completely closed air circuit at 4.0 bar.

45.7 Adjust locking lever

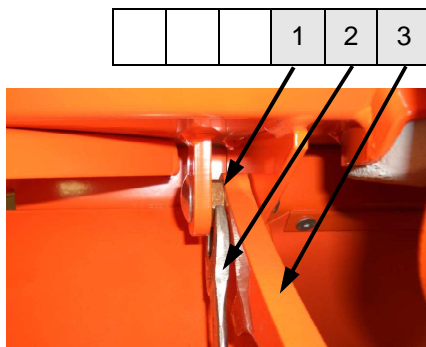

Fig. 101: Eccentric bushing

NOTE!
By turning the eccentric bushing (1) with the special wrench (2) in the tool bag, the locking lever (3) can be adjusted.

- Loosen locking lever and turn eccentric bushing.
- Close the locking lever and check if this action closes the mixing tube again tightly.

45.8 Measures after effected maintenance

1. After finishing the maintenance works and prior to switching on the machine, the following steps have to be carried out:
2. Check all previously loosened screw connections for secure fit.
3. Check if all previously removed safety systems and covers are properly reinstalled.



4. Ensure that all used tools, materials and other equipments were removed from the work area.
5. Clean the work area and remove any spilled materials such as liquids, processing material or similar.
6. Ensure that all safety systems of the installation work perfectly.

46 Disassembly

After the useful service life has been reached, the device has to be dismantled and disposed of in an environmental-friendly manner.

46.1 Safety

Personnel

- Disassembly must be carried out only by specially trained technical personnel.
- Work on the electrical system must be carried out by qualified electricians only.

Basic information



WARNING!
Risk of injury in case of improper disassembly!

Stored residual energies, sharp components, points or edges at and inside the device or at the required tools might cause injuries.

Therefore:

- Prior to starting the works ensure that there is sufficient space.
- Carefully handle components with sharp edges.
- Ensure order and cleanliness at the working place! Loose components and tools on top of another or lying about, pose potential accident risks.
- Dismantle components correctly. Pay attention to partly high dead weight of the components. If required use lifting equipment.
- Secure components that they do not fall down or fall over.
- In case of doubt, consult the dealer.

Electrical system



DANGER! **Danger of death from electric current!**

There is danger to life if you come in contact with live parts. Activated electrical components can carry out uncontrolled movements and cause serious injuries.

Therefore:

- Prior to beginning the disassembly, switch off the power supply and finally disconnect it.

46.2 Disassembly

Clean the device for phasing out and disassemble under observance of applicable health and safety rules as well as environmental regulations.

Prior to starting the disassembly:

- Switch off device and secure against restarting.
- Physically separate the complete energy supply to the device, discharge stored residual power.
- Remove operating supplies as well as remaining processing materials and dispose of in an environment-friendly way.

47 Disposal

If no agreement for the recovery or the disposal was made, recycle the disassembled components:

- Scrap metals.
- Recycle plastic elements.
- Dispose of remaining components, sorted according to the type of material.



ATTENTION! **Environmental damage in case of incorrect disposal!**

Waste from electronic and electrical equipment, electronic components, lubricants and other auxiliary materials are subject to hazardous waste treatment and must be disposed of by specialised companies only!

The local authority or special waste management operators can supply information on environmentally-friendly disposal.



48 Index

Accessories.....	17	Disassembly.....	62
Adjust locking lever.....	61	Disposal	63
Air compressor K2 N with pressure switch-off... 15		Division.....	8
Air filter compressor.....	59	Earlier damage to the mortar hose	47
Anti-dust unit G 4.....	33	EC Declaration of Conformity	6
Apply mortar.....	37	Emergency-stop switch.....	40
Assembly	13	Empty the mixing tube	49
Blockage does not dislodge.....	48	Environmental protection	58
Blow dry water fitting.....	56	Estrich	38
Causes for this can be:	47	Examination	7
Change the direction of rotation of the mixing pump motor in case of blockages in the hose 48		Examination by machine operator	7
Changing the pump / Cleaning the pump.....	54	Fault displays	43
Check consistency of mortar	34	Faults	43
Check the individual connectors.....	29	Feeding dry material to the machine.....	33
Clean mortar hose	51	Fields of application	21
Cleaning the G 4 X	50	Flowability / Flow characteristics.....	22
Cleaning the hopper	53	Fold up mixing tube.....	54
Cleaning the machine after work	49	Functional principle G 4 X SUPER / G 4 X XL... 21	
Cleaning the mixing tube	52	General information	8, 9
Close water draining cocks.....	29	General positioning of the air compressor	20
Compressed air supply	36	Hazardous dusts	32
Connect air hose.....	36	Hopper	14
Connect mortar hose	36	Hot surface of the air compressor.....	20
Connecting the power supply 400V	28	Idle-running protection	27
Connecting the spraying gun.....	37	In case of longer interruption of work/break.....	39
Connecting the water supply	30	Index	64
Connecting the water supply	29	Information regarding the operating manual.....	8
Connection of water from water tank.....	30	Insert agitator	53
Connections.....	16	Insert the mixing tube cleaner.....	52
Control cabinet item number 00 25 46 66	14	Intended purpose air compressor	19
Decouple mortar hose	50	Intended purpose control panel	18
Description G 4 X SUPER / G 4 XL.....	21	Intended purpose flow meter	18
Description of assemblies.....	14	Intended purpose solenoid valve	18
Dimension sheet.....	11	Intended use air compressor	19
Disassembly.....	63	Intended use control panel.....	18
		Interruption of work	39



Keep the manual for future reference.....	8	Removal of blockages in the hose.....	47
Maintenance	57	Remove connection cable	57
Maintenance plan	58	Remove the water hose.....	51
Maintenance work	59	Safety.....	43, 57
Maßblatt.....	11	Safety.....	26
Material.....	22	Safety.....	62
Measures after effected maintenance	61	Safety instructions for transport.....	23
Measures in case of power cut.....	41	Safety rules	22
Measures in case of risk of frost.....	55	Safety system	27
Mixing tube with motor and pump	15	Safety systems air compressor.....	20
Monitoring the machine	34	Safety valve air compressor	61
Mortar hoses.....	35	Secure against restarting.....	50
Mortar pressure gauge	22, 32	Selector switch pressure booster pump	16
Name plate	12	Selector switch star wheel	16
Open the air tap at the spraying gun	38	Set water quantity	31
Operating conditions.....	9	Setting value pressure switch air.....	61
Operating modes	16	Setting value pressure switch air compressor....	61
Operation	26	Setting value pressure switch water	60
Overview.....	13	Signs for hose blockages.....	46
Packaging.....	26	Soaking of the mixing section	32
Periodic inspection	7	Sound power level	11
Personnel		Spare parts lists	8
Disassembly.....	62	Start the machine in a.....	34
Installation.....	43	Stopping in case of emergency	40
Intial startup	43	Stopping in case of emergency Emergency-stop switch	40
Plastic screen	60	Strainer screen in pressure reducer	60
Power connection	9	Switch off air compressor	39
Power values Pump unit D6-3.....	10	Switch off G 4 X.....	55
Power values Pump unit D6-4.....	10	Switch on air compressor	37, 56
Prepare mortar hoses.....	35	Switch the machine back on after the blockage has been removed	49
Preparing the machine	28	Switching on the G 4 X	31
Protective gear		System monitoring	27
Installation.....	43	Table of faults	44
Putting the machine into operation.....	31, 34	Technical data	9
Quality Control sticker	12	Transport.....	24
Reaction in the event of faults	42	Transport in individual parts.....	25
Relieve mortar pressure	41	Transport inspection	24
Remote control	40		

Index



Transport with van	24	Water fitting	15
Transport, packing and storage	23	Work on troubleshooting	42
Vibrations	11	Working with the remote control	40





The FLOW OF PRODUCTIVITY



Knauf PFT GmbH & Co. KG
P.O. Box no. 60 97343 Iphofen
Einersheimer Straße 53 97346 Iphofen
Germany

Phone +49 9323 31-760
Fax +49 9323 31-770
Technical hotline +49 9323 31-1818
info@pft-iphofen.de
www.pft.eu